

Order-No. 674/11900

Tandem-Low bed trailer (loading area above axle) with sideways adjustable ramps, twin wheels

Weights:	total weight thereof tongue weight – depending on drawing vehicle maximum payload in standard model approx. empty weight approx.	11900 Kg 1000 kg 9150 kg 2750 kg
Measures:	loading area inside approx. (length x width) side height loading height empty approx. drawbar length approx coupling height empty approx. total measures length x width approx.	5000 x 2450 mm 400 mm 850 mm 1800 mm max. ca. 1020 mm 7150 x 2550 mm
Ramps:	length approx. width approx. elevation approx.	2500 mm 600 mm 14° degrees
Tyres:	Size	215/75 R 17,5 8-times

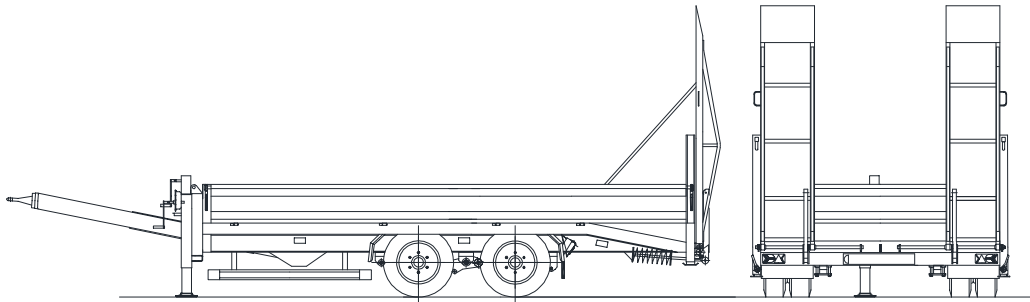

- Axles:** Fast-running BPW axles with cam brakes, maintenance-free parabolic spring assembly and weight adjustment
- Brakes:** Pressure air brake **EBS (24V) with TEM** (automatic park brake), testing sockets, connection hoses with mix-up safe couplings and **spring-loaded brakes**
- Drawbar:** Drawbar made of hot-manufactured hollow profile of quality S355, continuously adjustable with a winch, with a truck drawbar eye (40mm), adjustable in the height from approx. 0,72cm up to 1,02m
- Chassis frame:** sturdy electro welded steel construction made profile steel (IPE and UNP profiles of the quality S355); through short distances between the cross beams for high punctual load appropriate; side protection, stronger underrun protection reg. ECE R58-03
- Upper body:** Sidewalls laser welded; front wall fixed, sidewalls are swingable and removable; *with retractable lashing hooks with 3000daN lashing capacity mounted at a distance of 1,20m in the side profile, lashing hook every 60cm possible*, lash eyes in the corners with 4000daN. Larch-wood floor impregnated, with tongue and groove, 40mm strong; approx. 1,00m of the loading area is bevelled in the back, **rear corner posts removable up to the edge of loading area; lashing case instead of lashing hook, steel panel sideways removable; lashing straps to secure ramps – drive up width not restricted**
- Support:** Support winch of 10t in front with load and fast gear, two parking supports in the corner posts in the back assured by support legs
- Ramps:** Sideways adjustable steel ramps with wooden floor inlay and back beam; with adjustable steel springs as easy lift support for one-man-control, ramps lockable with tension lock, **ramps secured by lashing straps**
- Electric:** Splash water resistant lighting according to ECE-directive ECE-R 48.03 (Multi-chamber light, securely attached in underrun protection, **LED-track-**, position- and marker lights sideways); 24 voltage, 7+7 - or 15-pole depending on customer's request
- Varnishing:** Steel parts are steelgrain-blasted, pretreatment with iron phosphate; corrosion blocking zinc phosphate-base coat, electro statically primed and varnished in two Acryl-RAL customer chosen colour (High-Solid), then cavity sealing with conserving wax
- Accessories:** Two brake shoes with handle, Anti-splash mats, COC/EC Type approval, contour marking in accordance with ECE-R 104