

Order-No. 545/5000

Tandem-Machine transport trailer (loading area between axles) with sideways adjustable ramps, with EC type-approval/COC

Weights:	total weight thereof supportive load maximum payload in standard model approx. empty weight approx.	5000 kg 500 kg 3550 kg 1450 kg
Measures:	loading area inside approx. (length x width) side height loading height empty approx. drawbar length approx coupling height empty approx. total measures length x width approx.	3500 x 1750 mm 370 mm 580 mm 1800 mm max ca. 1020 mm 5480 x 2280 mm
Ramps:	length approx. width approx. elevation approx	2000 mm 450 mm 17° Grad
Tyres:	Size	215 R 14C 4-times

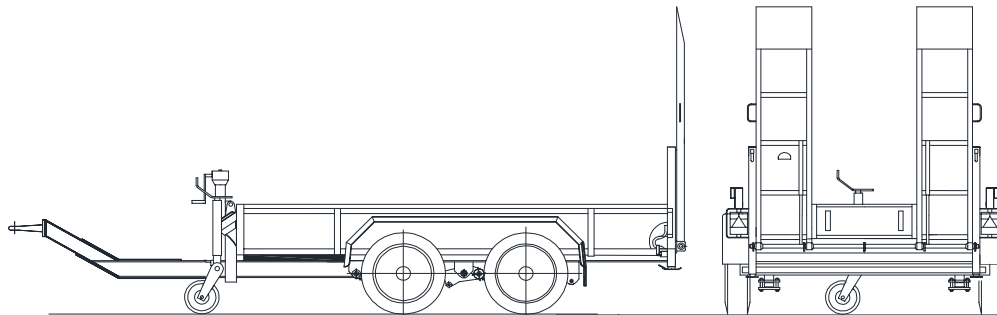

- Axles:** Knott fast-running axles with leaf springs, cam break and weight adjustment
- Brakes:** Pressure air brake with release valve, ALB, testing sockets, connection hoses with mix-up safe couplings, 24V-antilock braking system (ABS), immobilisation brake
- Drawbar:** Drawbar made of hot-manufactured steel shade of quality S355, continuously adjustable with a winch, with a truck drawbar eye (40mm), adjustable in the height from approx. 0,72cm up to 1,02m
- Chassis frame:** self-supporting, buckling resistant frame, sturdily electro welded steel construction made of steel plates
- Upper body:** Sidewalls made of steel, front- and sidewalls are strengthened, all steel parts are welded, mud guard made of edged steel plate, solidly welded and accessible with clearpass flap, plywood wall (made of 18mm strong plywood) between the ramps; lashing hooks in the corners: front hooks with 2500daN, back hooks with 3500daN, two pair of lash rings embedded in the trailer bottom (approx. 1,25m in between) with 2500daN; impregnated wooden bottom made of spruce wood with tongue and groove 34mm strong, with side protection, with stronger underrun protection reg. R58-03
- Support:** Adjustable support wheel in front, two parking supports in the corner posts in the back assured by support legs
- Ramps:** Sideways adjustable steel ramps with wooden panel; gas-filled shock absorber for lifting support, ramps can be locked by quick release clamps
- Electric:** Lighting according to ECE-directive ECE-R 48.03 (Multi-chamber light, attached in the steel frame, position lights in front); 24 voltage, 7- or 15-pole depending on customer's request
- Varnishing:** Steel parts are steelgrain-blasted, pretreatment with iron phosphate; corrosion blocking zinc phosphate-base coat, electro statically primed and varnished in Acryl-RAL customer chosen colour (High-Solid), then cavity sealing with conserving wax
- Accessories:** Two brake shoes with handle; Anti-splash mats; EC type approval (COC), homologation documents